

# SN5407, SN5417, SN7407, SN7417 HEX BUFFERS/DRIVERS WITH OPEN-COLLECTOR HIGH-VOLTAGE OUTPUTS

SDLS032G – DECEMBER 1983 – REVISED MAY 2004

- Convert TTL Voltage Levels to MOS Levels
- High Sink-Current Capability
- Input Clamping Diodes Simplify System Design
- Open-Collector Driver for Indicator Lamps and Relays
- Inputs Fully Compatible With Most TTL Circuits

## description/ordering information

These TTL hex buffers/drivers feature high-voltage open-collector outputs for interfacing with high-level circuits (such as MOS) or for driving high-current loads (such as lamps or relays) and also are characterized for use as buffers for driving TTL inputs. The SN5407 and SN7407 have minimum breakdown voltages of 30 V, and the SN5417 and SN7417 have minimum breakdown voltages of 15 V. The maximum sink current is 30 mA for the SN5407 and SN5417 and 40 mA for the SN7407 and SN7417.

These devices perform the Boolean function  $Y = A$  in positive logic.

SN5407, SN5417 . . . J OR W PACKAGE  
SN7407, SN7417 . . . D, N, OR NS PACKAGE  
(TOP VIEW)

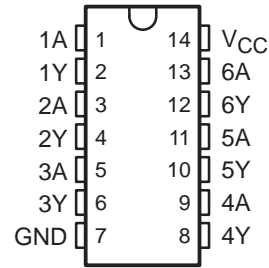

SN5407 . . . FK PACKAGE  
(TOP VIEW)

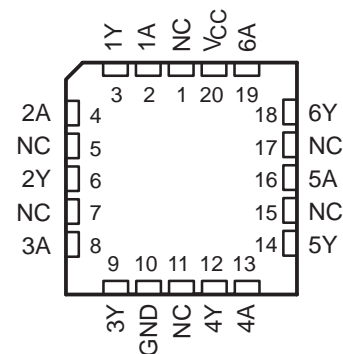

NC – No internal connection

## ORDERING INFORMATION

T <sub>A</sub>	PACKAGE†		ORDERABLE PART NUMBER	TOP-SIDE MARKING	
0°C to 70°C	SOIC – D	Tube	SN7407D	7407	
		Tape and reel	SN7407DR		
		Tube	SN7417D	7417	
		Tape and reel	SN7417DR		
	PDIP – N	Tube		SN7407N	SN7407N
				SN7417N	SN7417N
SOP – NS	Tape and reel		SN7407NSR	SN7407	
			SN7417NSR	SN7417	
–55°C to 125°C	CDIP – J	Tube	SNJ5407J	SNJ5407J	
			SNJ5417J	SNJ5417J	
	CFP – W	Tube	SNJ5407W	SNJ5407W	
			SNJ5407FK	SNJ5407FK	

† Package drawings, standard packing quantities, thermal data, symbolization, and PCB design guidelines are available at [www.ti.com/sc/package](http://www.ti.com/sc/package).



Please be aware that an important notice concerning availability, standard warranty, and use in critical applications of Texas Instruments semiconductor products and disclaimers thereto appears at the end of this data sheet.

PRODUCTION DATA information is current as of publication date. Products conform to specifications per the terms of Texas Instruments standard warranty. Production processing does not necessarily include testing of all parameters.

 **TEXAS  
INSTRUMENTS**

POST OFFICE BOX 655303 • DALLAS, TEXAS 75265

Copyright © 2004, Texas Instruments Incorporated  
On products compliant to MIL-PRF-38535, all parameters are tested unless otherwise noted. On all other products, production processing does not necessarily include testing of all parameters.